

# *Scorpio 23'*



*High speed, smooth and silent.*



**DOLLY WITH ARTICULATED  
WHEELS, BRAKES AND  
LEVELING JACKS**

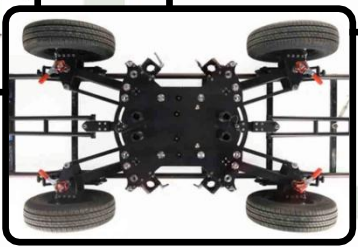
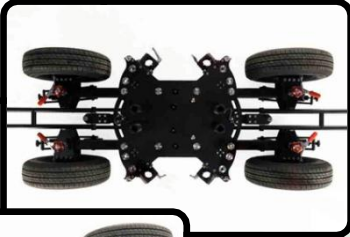
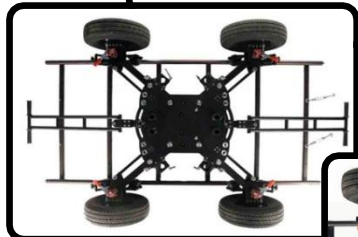

**INCORPORAES AN EXCLUSIVE  
"DYNAMIC COUNTERWEIGHT SYSTEM"**

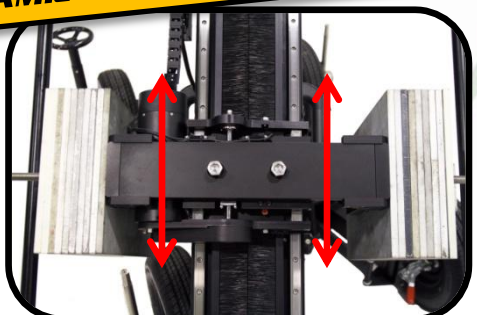

**REMOVABLE  
TRAVELLING WHEELS**





## Features:

- Dynamic Counterweight System: Electronic adjust for the counterweight support activated automatic or by the hand command.
- The arm-fulcrum, as the column or the dolly are totally independents from each other. It's possible to assembly the arm (fulcrum included) in other column or dolly for special needs.
- Automatic compensator of the arc generated by the movement of the arm in both horizontal and vertical.
- Programmable limits on the telescopic movement of the arm.
- Movement generator of the telescopic arm in relation to the horizontal or vertical movement.
- Arm speed adjustable and displayed on the screen.
- Arm stop damping adjustable and displayed on the screen.
- Overslung and Underslung capability
- Screen display of the arm range, vertical and horizontal angles, height to the optic axis in meters and feet.
- Programmable stop sequence.
- TILT, PAN and arm encoder reading for the Motion Capture jobs.
- Smooth movement in both high and slow speed.
- Noise reduction system of the telescopic arm movement.
- Mechanical lift for the telescopic column.
- Adjustable width with articulated arms with lockable positions.
- Tracking wheels: Adjustable to all track gauges: 0.62 m (2') and 1 m (3' 3").
- Pneumatic wheels: Adjustable width from 0.735 m (2' 5"), and 1,44 m (4' 8").

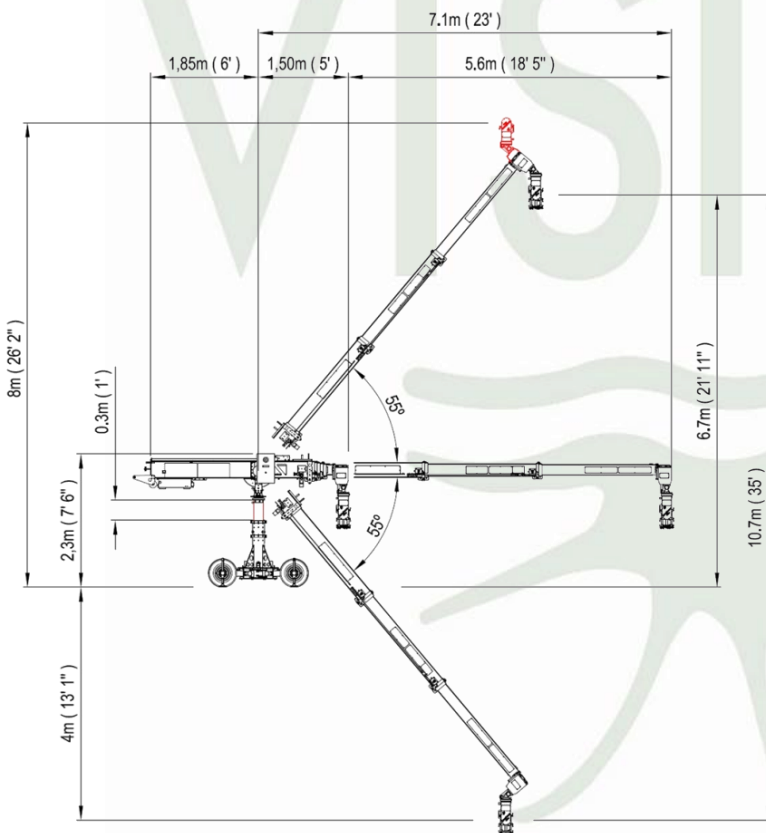

## 0.62 m (2') TRACKS

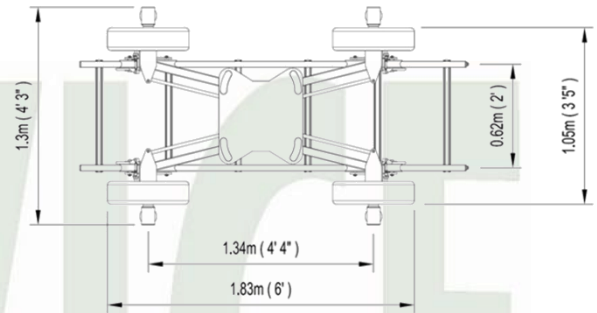

## 1 m (3' 3") TRACKS

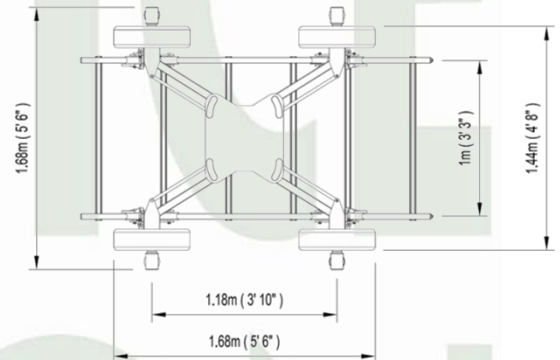

## SMALLEST CONFIGURATION (FOR TRANSPORT ONLY)

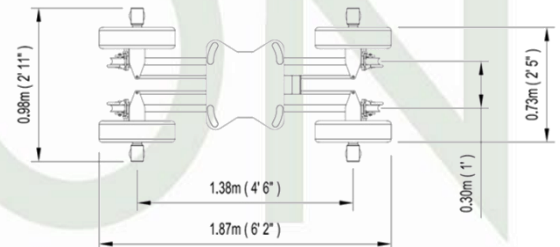

## Technical specifications:

- Maximum length: 7.1 m (23')
- Minimum length: 1.5 m (5')
- Back length of the arm: 1.85 m (6')
- Telescopic range: 5.6 m (18')
- Max. optical axis height: 6.7 m (21')
- Telescopic column maximum extension: 0.3m (1')
- Weight: 600 kg (1322.8 lb)
- Max. Weight with counterweight: 1100 kg (2425 lb)
- Loading capacity in Underslung position: 70 kg (154lb)
- Loading capacity in Overslung position: 35 kg (77lb)
- Required power: 220 V / 16 A - 110 V / 16 A
- Output power for the remote head: 30 V / 20 A
- Output power for the monitor: 12 V / 3 A
- Max. speed: 1.8 m/s

## SERVICEVISION BIS S.L.

Calle Ríos Rosas, 20  
08940 Cornellà de Llobregat  
Barcelona, Spain  
Phone +34 93 2238630  
Fax +34 93 2238631  
comercial@servicevision.es  
[www.servicevision.es](http://www.servicevision.es)



@servicevision



@servicevision\_scorpio



@ServicevisionScorpio